



### Features:

- This controller is perfect solution for application involves heating+cooling control, typically, the output 1 will be heating, output 2 will be cooling, widely used in plastic extrusion and other industrial heating+cooling control area
  - Dual display,4 digits,7 segments LED display
  - TC / RTD input, analog universal input
  - PID,PID Autotune, ON-OFF,time proportional
  - Auto/manual control bumpless transfer
  - 0.2%F.S measuring accuracy
  - Bar graphic display indication
  - °C/°F display selectable
  - Alarm standby function
  - Soft-start function for analog output
- Optional features**
- 24VDC auxiliary power supply
  - RS485 modbus RTU communication

### Technical Specifications

#### Ordering Information

FT100 without Auto/manual switch key  
FT101 with auto/maual switch key

<b>FT100</b> (48mm*48mm)(Width*Height)	1	2	3*	4	5	6	7
<b>FT101</b> (48mm*48mm)(Width*Height)							
<b>FT400</b> (48mm*96mm)(Width*Height)							
<b>FT500</b> (96mm*48mm)(Width*Height)							
<b>FT700</b> (72mm*72mm)(Width*Height)							
<b>FT900</b> (96mm*96mm)(Width*Height)							

#### 1:Output 1(heating control)

<b>R</b>	Relay output
<b>V</b>	SSR Drive/Voltage pulse output
<b>D</b>	4-20mA output

#### 2:Output 2(cooling control)

<b>R</b>	Relay output
<b>V</b>	SSR Drive/Voltage pulse output
<b>D</b>	4-20mA output

#### 3:Number of Alarms

<b>1</b>	1 alarm
<b>2</b>	2 alarms

#### 4:Power Source

<b>96</b>	85~265Vac 50/60HZ
<b>24</b>	24Vac/24Vdc

#### 5:Communication

<b>N</b>	Without Communicaiton
<b>K</b>	With Modbus RTU RS-485 communication

#### 6:Auxiliary Power Supply

<b>N</b>	Without auxiliary power
<b>24</b>	24VDC Auxiliary Power Supply

Example: FT100-R-R-1-96-NN( FT100, size 48mm\*48mm, output 1 relay, output 2 relay, 1 alarm, 85~265Vac)

#### Display

Digits	4 digits 7 segments LED,Dual display
LED Indicators	OP1,OP2,AT,AL1,AL2,AL3,MAN,COM,PRG

#### Input Specifications

Inputs	Thermocouple(K,J,R,S,B,T,E,N,Wu3_Re25) RTD(PT100) DC Analog Inputs(2-10Vdc,1-5Vdc,4-20mA) (0-10Vdc,0-5Vdc,0-20mA) (0-50mV,0-20mV)
Sampling time	500ms
Input Filter(FTC)	0 to 66( 1-30 normal, 31-60 enhanced)
Resolution	1/0.1° for TC/RTD only Decimal point position selectable: 1/0.1/0.01/0.001 for analog input
Temperature Unit	°C/°F Selectable
Indication Accracy	For TC inputs: 0.2% of F.S. ± 1° For R & S type TC inputs: 0.5% of F.S. ± 2° (20 min of warm up time for TC inputs) For RTD inputs: 0.2% of F.S. ± 1° For Analog input: ± 0.5%. ± 1 digit (F.S.=Full Scale)

#### Output Specifications

Main Control Output	1 main output, heating or cooling selectable
Contact Rating(SPST)	5A @ 250Vac Resistive Load(Main Output) 3A @ 250Vac Resistive Load(Alarm output)
Current	0/4 to 20mA DC(loop impedance: 500Ω max.)
SSR Drive	12V DC(20mA)
<b>Retransmission</b>	
Current	4 to 20mA DC(loop impedance: 500Ω max.)
Voltage	0 to 10Vdc(Load resistance: 10KΩ Min)

#### Supply Voltage

Supply Voltage	85~265Vac 50/60HZ
Power Consumption	6VA max @230Vac

#### Environmental Specifications

Temperature	Operating: 0 to 50°C(32 to 122°F) Storage: -20 to 75°C(-4 to 167°F)
Humidity(non-condensing)	95%RH
Weight	0.17kg
Protection	Dust proof for front plate

### Heating and Cooling Control

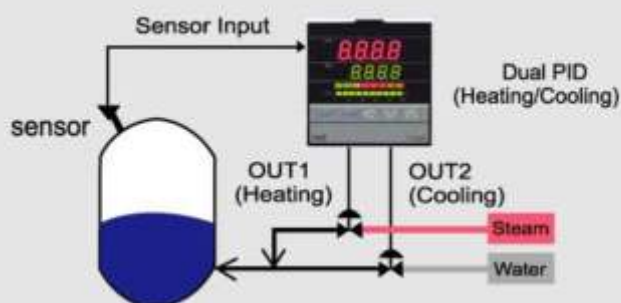

**Functional Specifications**

Control Action	1)PID 2)ON-OFF, when P=0 3)Time proportional when P≠0 I=0 D=0
Proportional Band(P)	0.0 to 200.0
Integral Time(I)	0 to 3600 sec
Derivative Time(D)	0 to 3600 sec
Cycle Time	0 to 999 sec
Hysteresis Width	0.0 to 100.0
Manual Control Power	0 to 100%
Alarms modes	Deviation high / Deviation low Deviation high/low alarm Deviation band alarm Process high alarm/ Process low alarm
Input offset	-199 to 199
Auto-tune offset	0 to 199.0°
Output lower limit	0.0 to 100%
Output higher limit	0.0 to 100%

**Optional features**

Auto/manual control	48mm*48mm, 1/16DIN also available for this function(Model FT101)
<b>Remote setpoint input</b>	
Inputs	4-20mA,0-20mA,0-10mA,0-5Vdc,0-10Vdc 1-5Vdc, 2-10Vdc
Input resistance	100 ohm
Range	-5% to 105%
Scale range	-1999 to 9999 with fixed 10 for TC/RTD as per resolution selected for analog input
<b>Serial communicaiton</b>	
Interface standard	RS-485
Communication address	0 to 127, maximum 36 units per line
Transmission mode	Half duplex
Transmission protocol	Modbus RTU
Transmission format	Support 03 read command, 06 and 10 write command 1 start bit+8 digital bit+N+1 stop bit(8.N.1) 1 start bit+ 8 digital bit+N+2 stop bit(8.N.2)
Transmission speed	2400,4800,9600,19200(9600 default)

**Compliance**

IEC/EN 61326(EMI/EMC)
IEC/EN 61010 Revision 3 2010 Edition(Safety)

**Panel Layout**

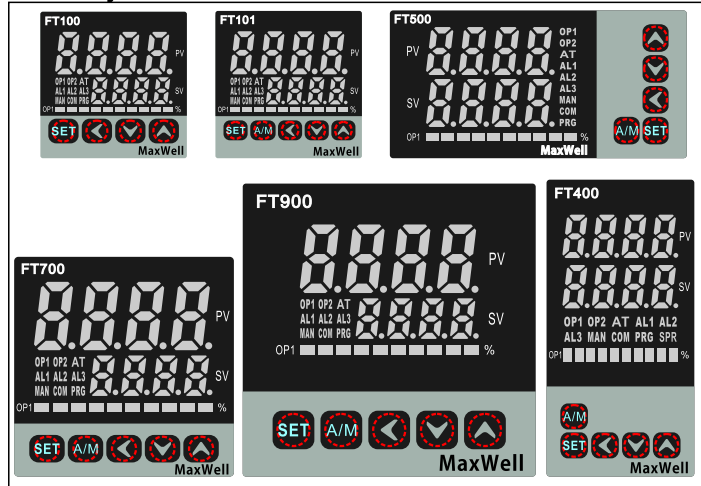

**Dimensions**

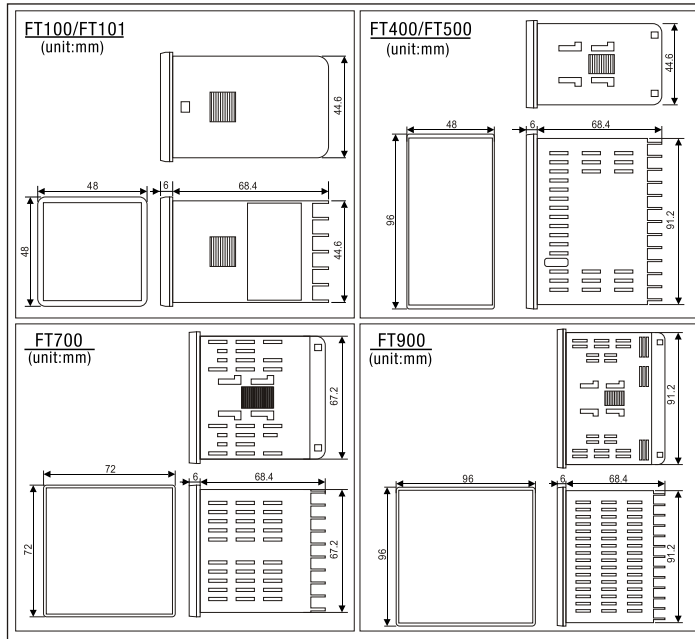

**Terminal Arrangement**

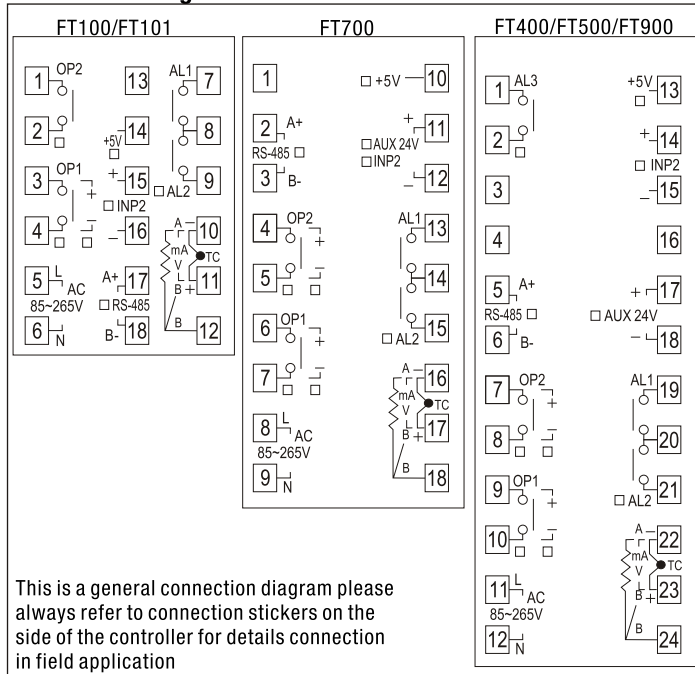

This is a general connection diagram please always refer to connection stickers on the side of the controller for details connection in field application

PV window, display PV or parameter notation  
SV window, display SV or parameter value  
Bar graphic, shows the output % or position  
feedback value 0-100%

- SET: Function key
- A/M: Auto/Manual transfer key and enter key
- ◀: Shift key
- ▼: Decrement key
- ▲: Increment key

- OP1 : Output 1 indicator
- OP2 : Output 2 indicator
- AT : Auto-tuning indicator
- AL1 : Alarm 1 indicator
- AL2 : Alarm 2 indicator
- AL3 : Alarm 3 indicator
- MAN : Manual control indicator
- COM : Communication indicator
- PRG : Reserved indicator
- SPR : Reserved indicator