

Customer (客戶): _____

Description (規格): AC FAN

Model No (型號): RGW17569B2HL

Sample Issue Date(送樣日期): _____

CONFIRMATION SIGNATURE 客戶承認欄	SIGNATURE 確認欄		
Please confirm your acceptance of this approval sheet by return fax. 本承认书内容若贵司确认无误， 请于上方承认栏内签章寄回。	APPD. 核准	EDAM. 審核	DRAW. 制表
	覃柯华	刘春松	黄丽平

**PRODUCT SPECIFICATION
APPROVAL SHEET**

產品規格承認書

一、 Sample Specification(樣品規格):

Item(項目)		Specification/Condition(規格/條件)	
01	Part No.(型號)	RGW17569B2HL	
02	Outline Dimension(外形尺寸)	Φ 175*69mm	
03	Rated Voltage(額定電壓)	AC230V	
04	Voltage Range(電壓範圍)	AC196V- 264V	
05	Frequency(頻率)	50/60Hz	
06	Rated Current(額定電流)	0.3/0.3A±10%	25°C 60~80%RH
07	Power Consumption(消耗功率)	56/69W±10%	25°C 60~80%RH
08	Speed(轉速)	2700/3100RPM±10%	25°C 60~80%RH
09	Weight(重量)	1200G	

二、 Electrical Specification(電氣規格):

Item(項目)		Specification/Condition(規格/條件)	
01	Dielectric Strength (絕緣耐壓)	1900V/2mA/5s	
02	Insulation Resistance (絕緣阻抗)	100 Meg Ohm Min. at 500VDC	
	Coil Resistance (线圈阻抗)	830±8%Ω	
03	Motor Protection(电机保护类型)	Impedance Protected	
04	Temperature Test of Run (運轉溫升)	N/A Rated Voltage(額定電壓)	
05	Locked Rotor Protection (鎖定檢測)	N/A Rated Voltage(額定電壓)	

三、 Safety Approvals(安規情況):

Safety Approvals (安規)	File No (安規編號)	Safety Approvals (安規)	File No (安規編號)
CE	18300RC40175401		

四、 Environmental Specification(環境條件):

Item(項目)		Specification/Condition(規格/條件)
01	Operating Temp. Range (工作溫/濕度範圍)	Temperature/溫度: -10°C~45°C Humidity/濕度: 35%~85%RH
02	Storage Temperature (保存溫/濕度範圍)	Temperature/溫度: -40°C~80°C Humidity/濕度: 35%~85%RH
03	Life (壽命)	50000H(At25°C/Relative Humidity 65%)

五、 Main Materials/Parts Specification(主要材料/零件規格):

Item(項目)		Specification(規格)
01	Impeller (叶轮)	PA plastic + 30% glass fiber
02	Stator& Rotor (定子与转子)	Fe/AL+Fe
03	Magnet Wires(漆包線)	Copper 2 UEW
04	Bobbin(絕緣套)	PA66
05	Bearing System(轴承类型)	Two Ball Bearing

六、 Outline Dimension(外觀尺寸圖):

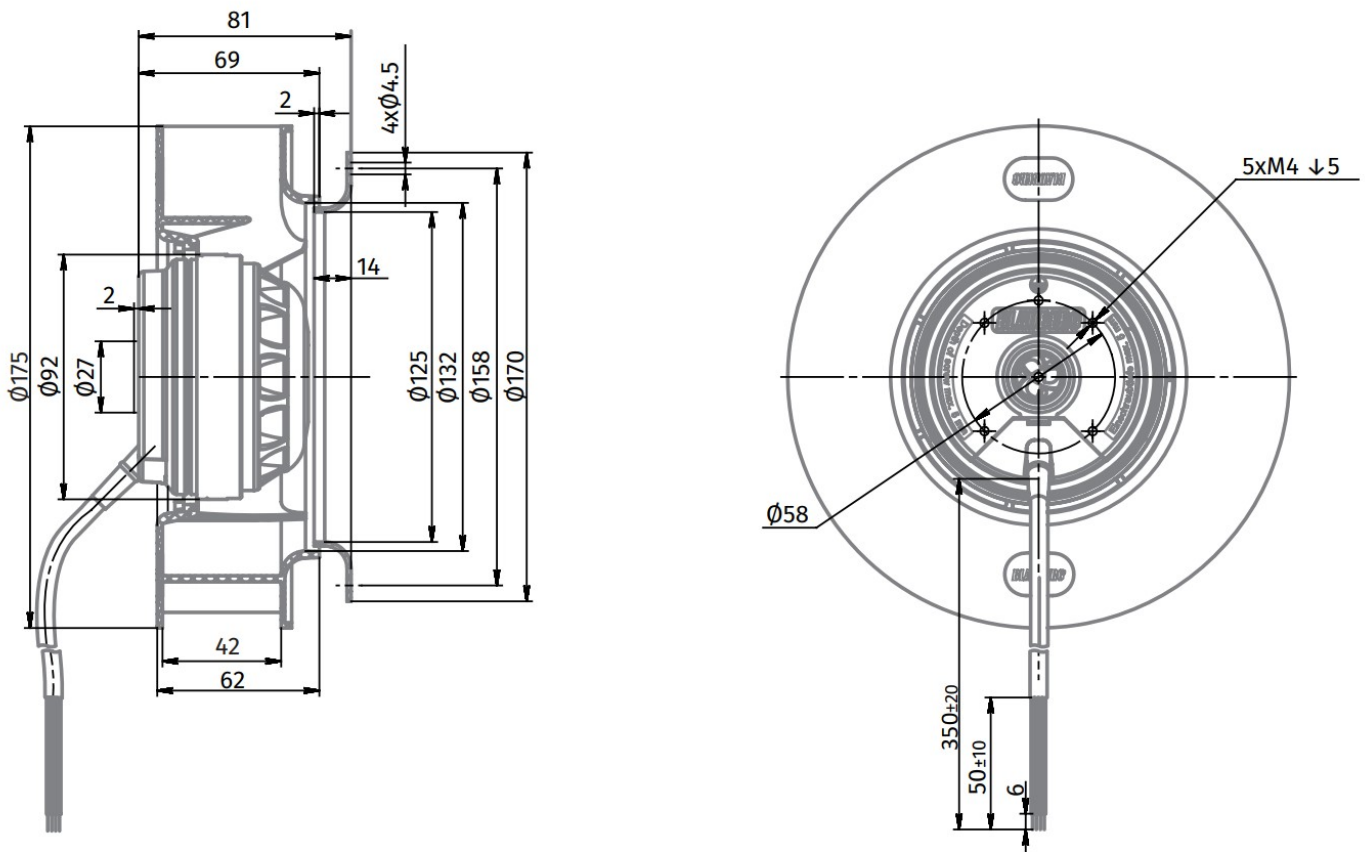

七、 ELECTRICAL CONNECTION DIAGRAMM (接线图)

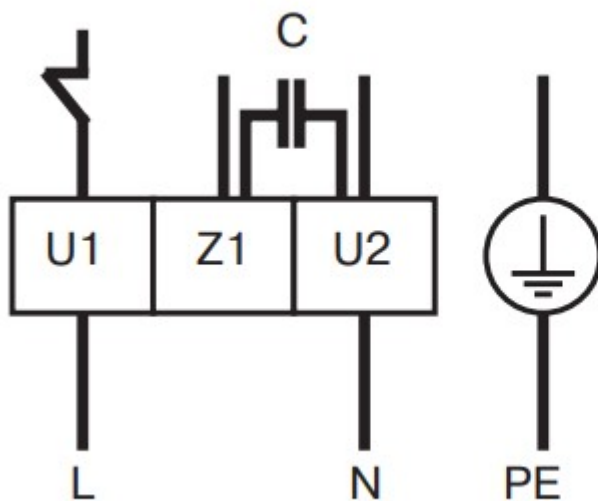

U1 Blue
 U2 Black
 Z1 Brown
 PE Green/Yellow

八、Property(特性圖):

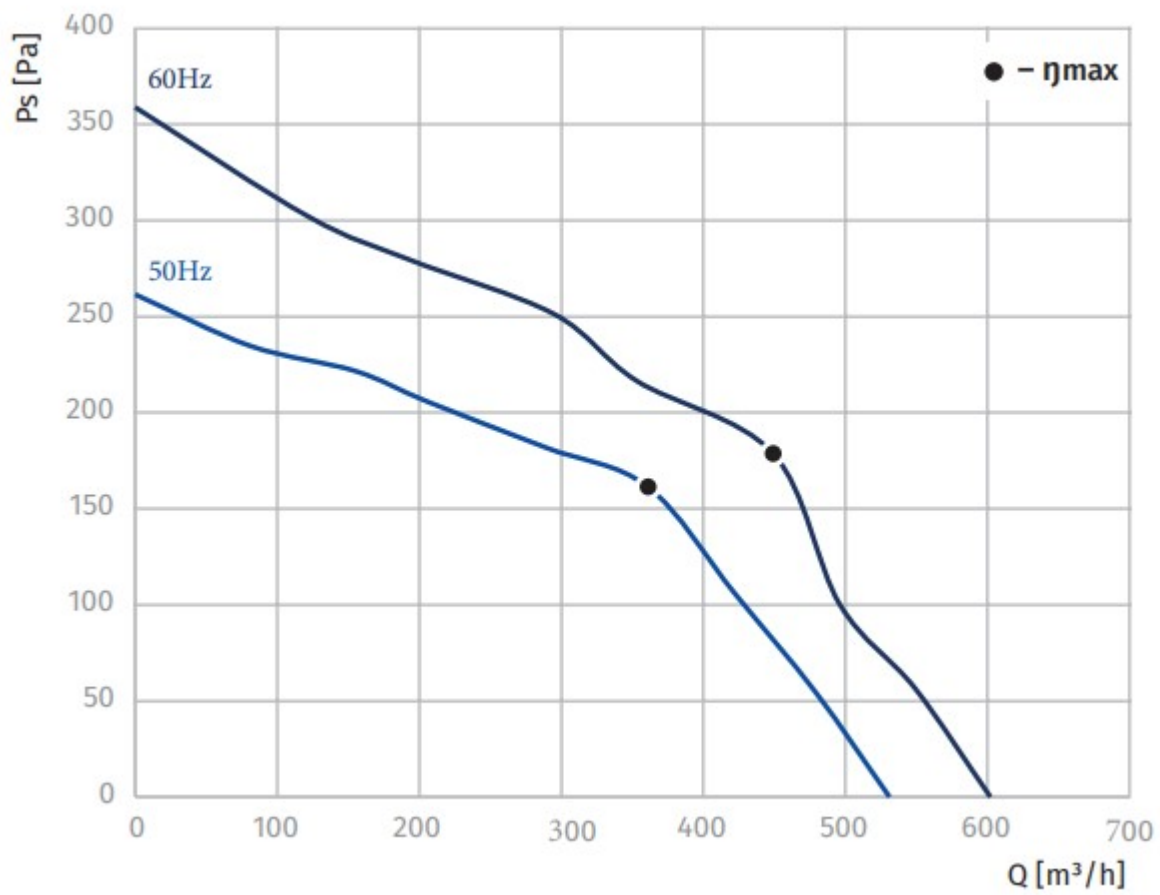

九、Model Explain(型號說明):

