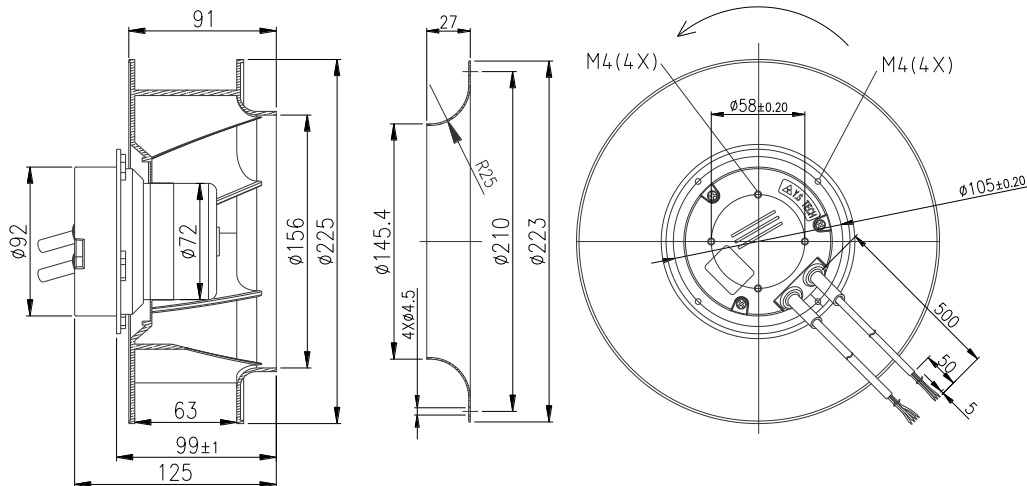

**EC Centrifugal fans 離心扇**
**backward curved 後傾式,  $\phi 225$** 

- **Material 材料:**  
 Impeller 扇葉: Glass fiber-reinforced polypropylene 玻纖強化聚丙烯  
 Electronics housing 後蓋: Die-casting aluminum 壓鑄鋁合金  
 Motor shell 馬達殼: Steel, electro deposited black 電著黑鋼材
- **Direction of rotation 轉動方向:** CW view toward rotor 看自入風口為順時針
- **Number of blades 葉片數:** 7
- **Degree of protection 防水防塵等級:** IP65
- **Mode of operating 操作模式:** Continuous operation S1 連續操作 S1
- **Insulation class 絕緣等級:** B
- **Installation position 安裝方向:** Any 任何

**Outline dimension 外觀尺寸**

The fan air inlet guide entering depth is 2mm  
 入風圈進入扇葉入風口深度為 2mm

**Technical parameters 規格參數**

Model name 機型編碼	QV222563HBL-7A2
Rated voltage 額定電壓(VAC)	230
Frequency 交流電頻率(Hz)	50/60
Current 電流(A)	0.67
Speed 轉速(RPM)	2,500
Power 功耗(W)	70
Max. airflow 最大風量(cfm)	566
Max. airflow 最大風量(m <sup>3</sup> /h)	962
Max. static pressure 最大靜壓(inAQ)	2.17
Max. static pressure 最大靜壓(Pa)	542
Noise 噪音(dBA)	66.1
Operating temperature 操作溫度(°C)	-25~60
Weight 重量(g)	1,450
Speed control 速控模式	0~10VDC/PWM

**Performance curves 性能曲線**
