

EC Centrifugal fans 離心扇

backward curved 後傾式, $\phi 175$

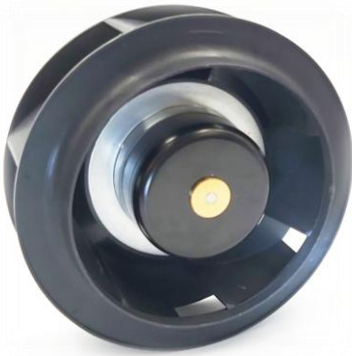

- **Material 材料:**
Impeller 扇葉: Glass fiber-reinforced polypropylene 玻纖強化聚丙烯
Electronics housing 後蓋: Die-casting aluminum 壓鑄鋁合金
Motor shell 馬達殼: Steel, electro deposited black 電著黑鋼材
- **Direction of rotation 轉動方向:** CW view toward rotor 看自入風口為順時針
- **Number of blades 葉片數:** 7
- **Degree of protection 防水防塵等級:** IP65
- **Mode of operating 操作模式:** Continuous operation S1 連續操作 S1
- **Insulation class 絕緣等級:** B
- **Installation position 安裝方向:** Any 任何

Outline dimension 外觀尺寸

The fan air inlet guide entering depth is 2mm
入風圈進入扇葉入風口深度為 2mm

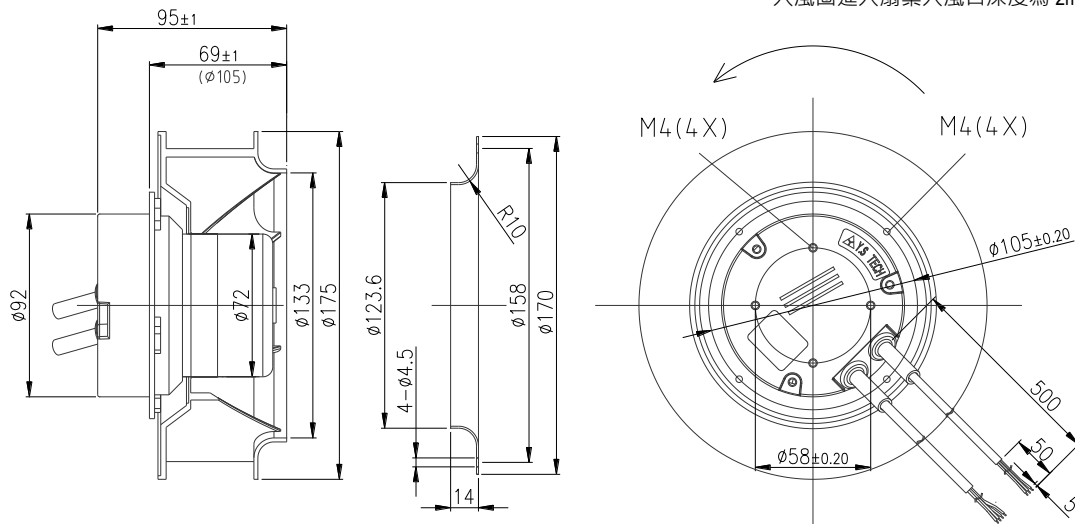

Technical parameters 規格參數

Model name 機型編碼	QV217542HBL-7A2
Rated voltage 額定電壓(VAC)	230
Frequency 交流電頻率(Hz)	50/60
Current 電流(A)	0.95
Speed 轉速(RPM)	4,640
Power 功耗(W)	110
Max. airflow 最大風量(cfm)	458
Max. airflow 最大風量(m ³ /h)	779
Max. static pressure 最大靜壓(inAQ)	3.54
Max. static pressure 最大靜壓(Pa)	884
Noise 噪音(dBA)	75.2
Operating temperature 操作溫度(°C)	-25~60
Weight 重量(g)	1,218
Speed control 速控模式	0~10VDC/PWM

Performance curves 性能曲線

