

TECHNICAL SPECIFICATION:

1. All parts of fan should be properly assembled, no oil or dirt on the surface, no obvious distortion, mechanical damage and other defects.
2. Fan rotation is flexible, no delay no operation sound, no scratch and other undesirable phenomena.
3. The safety requirement of fan is performed according to GB12350-2009, the electrical strength is 1500V•min, and the insulation resistance is not less than 100M Ω at room temperature.
4. Motor insulation class, F CLASS.
5. Motor protection level, IP44, fan protection level, IP2X.
6. The fan balance level is: 1390± 10% r/min high G6. 3, vibration value is less than 5.4mm/s.
7. MAER box.
8. Built-in heat protector.



Product model	YSWF102L35P4-570N-500S
Product type	External rotor axial flow fan
Customer	乌克兰 (Ukraine)
Product number	MAER - 150301D
Certification	CE, CCC

Condition of use:

- 1) Voltage and frequency: 3 ~ 380V + 5% (50 Hz)
- 2) Qualification requirements: Terminal block, the recommended standard of lead wire is not less than 0,75mm².
- 3) Installation position: vertical or upward.
- 4) Ambient temperature: -40 ~ 80°C.

THE EXTERNAL WIRING DIAGRAM:

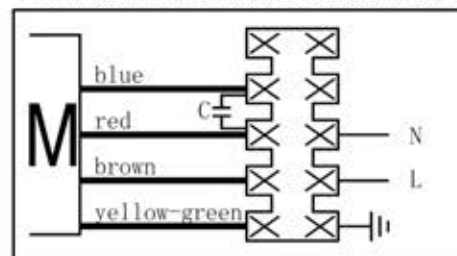

WIRING DIAGRAM

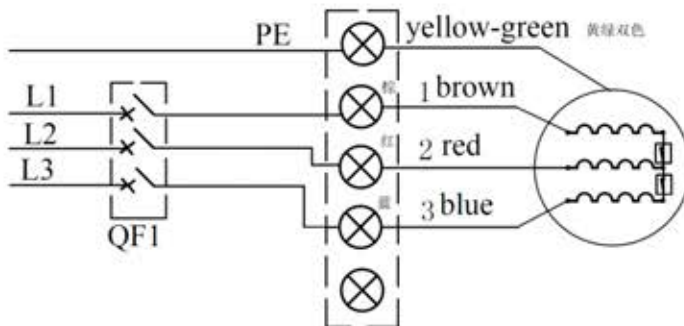

MARK

MAER AXIAL FAN MOTOR
MOTORS & FANS

MODEL: **YSWF102L35P4-570N-500 SUCTION 4D-500-S**

VOLTAGE: 380V / 50Hz

N.W/G.W. 9.3/10.8 kg

MEAS: 55x55x21 cm

CL. F WITH TERMINAL BOX

20180509X

Test data at free:

Connection	UAC (V)±5%	f (Hz)	P1 (W)±10%	I (A)±10%	n (r/min)±10%	Noise db(A)
	3-380V	50	390	0.76	1390	70

Performance parameters at key point:

	psf (pa)	I (A)	P1 (W)	n (r/min)	Q (m ³ /h)	Note
①	0	0.72	349	1380	6460	
②	64	0.78	405	1356	5635	
③	117	0.83	449	1332	4483	MAX EFF.
④	139	0.83	455	1327	3501	IMAX

PS: Fan working performance tested with MAER wall plate, and under standard atmospheric pressure at 20°C

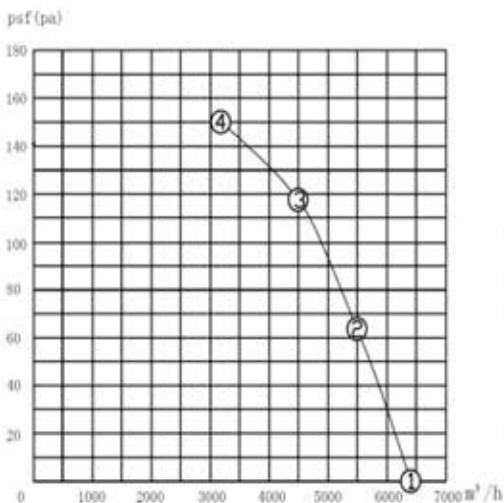

Nameplate:



YSWF102L35P4-570N-500 S 3~380V50Hz 10μF / 450V
449W 0.83A 1332r/min @ 117Pa
CL. F IP54 2018/05

state	Deliver before	The signature	(date)(month)(year)	ZHEJIANG MAER FAN MOTOR CO., LTD.
	After the confirmation			
drawing				Product Specification
audit				
approval				