

# 常州市创联电源科技股份有限公司

Changzhou Chuanglian Power Supply Technology Corporation

## 承认书

### CERTIFICATE FOR CONFIRMATION

客户名称 ( CUSTOMER ) : \_\_\_\_\_  
客户料号 ( PART NO. ) : \_\_\_\_\_  
产品名称 ( PART NAME ) : Switching Power Supply  
产品规格 ( DESCRIPTION ) : A-100FAN  
编制日期 ( DATE ) : \_\_\_\_\_

制定 (Engineer)	审核 (Supervisor)	核准 (Engineer Manager)
承认 (Engineer)	审核 (Supervisor)	核准 (Engineer Manager)

注:此承认书一式二份,请签核完后寄回我司一份保存。

Remark:This certification is in duplicate,please send us a copy signing.

厂商:常州市创联电源科技股份有限公司  
地址:江苏省常州市钟楼经济开发区童子河西路8号

电话:86-519-85215050, 85210525

传真:86-519-85215252, 85215770

网址:www.haitaik.com

邮箱:ad@haitaik.com

Mfr.:Changzhou Chuanglian Power Supply Tech Corp

Address:No. 8, Tongzihe West Road, Zhonglou Economic Development Zone, Changzhou, Jiangsu 213024, China

Tel:86-519-85215050, 85210525

Fax:86-519-85215252, 85215770

Web:www.haitaik.com

E-mail:ad@haitaik.com

编号:



# A-100FAN Switching Power Supply



## ◆ Features

- Universal AC input
- No load power consumption < 0.3W
- Cooling by free air convection
- Protections: short circuit/overload
- 100% pass aging test
- 3 years warranty

## General Specifications

Model No.	A-100FAN-5	A-100FAN-12	A-100FAN-24	A-100FAN-36	A-100FAN-48	
Output	DC voltage	5V	12V	24V	36V	48V
	Rated current	18A	8.5A	4.5A	2.8A	2.3A
	Current Range	0~18A	0~8.5A	0~4.5A	0~2.8A	0~2.3A
	Rated power	90W	102W	108W	101W	110W
	Ripple & Noise	100mVp-p	150mVp-p	200mVp-p	200mVp-p	200mVp-p
	Voltage regulating range	±10.0%				
	Voltage accuracy	≤1.0%				
	Line regulation	≤1.0%				
	Load adjustment rate	≤1.0%				
	Rise	≤30ms / rated load				
Hold up time (Typ)	30ms/ rated load					
Input	Voltage range	85~264VAC;				
	Frequency	47~63HZ				
	PFC (Typ)					
	Efficiency (Typ)	86%	88%	90%	90.5%	91%
	Alternating current	MAX 1.9A/115V 1.2A/230V				
	Inrush current (Typ)	50A/230VAC				
Protec tions	Leakage current	<0.75mA/240VAC				
	Overload	120~150% of rated output, auto-recovery				
	Short circuit	Hiccup mode, auto-recovery				
	Over Voltage	120%-140% rated output voltage, Shut down o/p voltage, re-power to recover				
Enviro ment	Working temp.	-30℃~+70℃ (refer to output derating curve)				
	Working humidity	20~95%RH non condensing				
	Storage temp.	-40℃~+80℃				
	Storage humidity	10~95%RH non condensing				
	Temp. coefficient	±0.03%/℃ (0~50℃)				
	Vibration resistance	10~500Hz, 5G, 10min/cycle, X、Y、Z 60min in each direction				
Safety	Safety standards	design accoring to UL60950-1, EN60335-1, CCC GB4943				
	Withstand voltage	I/P-0/P:3KV AC、I/P-FG: 2KV AC、O/P-FG: 0.5KV AC				
	Isolation Resistance	I/P-0/P、I/P-FG、O/P-FG: 100MΩ/500VDC/25℃/70%RH				
	EMC	EN55022				
Others	Lifetime	380,000 hours (25℃)				
	Size	129×97×30 (L*W*H)				
	Weight	0.34Kg/pc				
Rmarks	<p>*In order to extend the lifetime, it is recommended to configure the load no more than 30% of the remaining allowance. For example: the power of the device requires 100W, then use the power of less than 130W.</p> <p>*Ripple test method: 20MHz oscilloscope in power output terminal test, oscilloscope probe wire length is not more than 12mm, and input parallel 47uF electrolytic capacitors and 0.1uF high frequency</p>					



## Load temperature drop curve

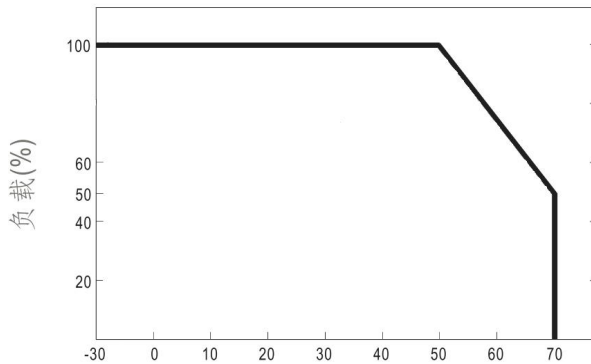

环境温度 (°C)

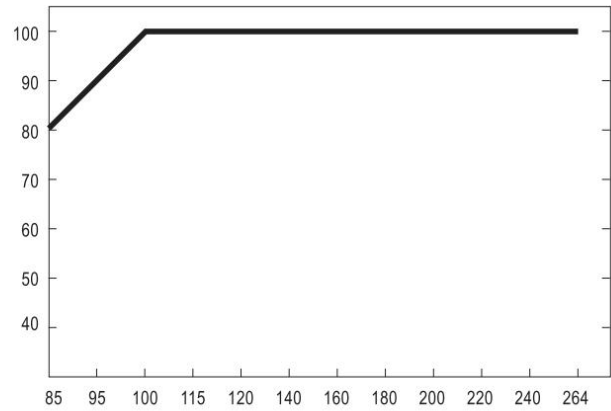

输入电压 (VAC) 60Hz

## Installation

### 警示

### Warning

- 使用安装螺丝M3\*6mm,  
Using the mounting screws M3\*6mm
- 深入外壳螺丝深度MAX 4mm,  
Deep housing screw depth Max 4mm
- 详见右图  
As shown on the right

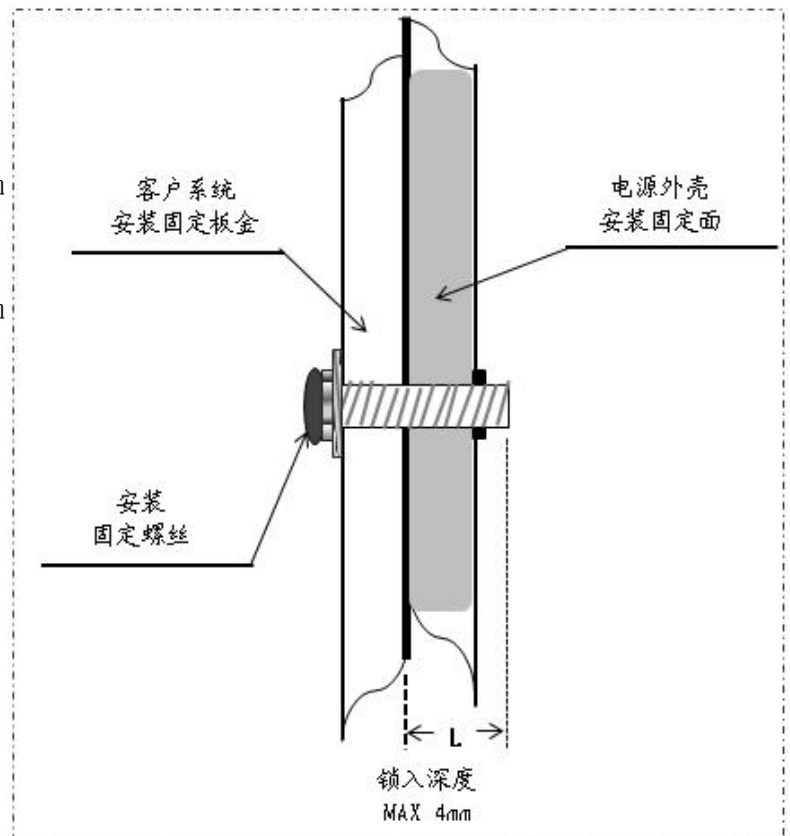



Drawing:

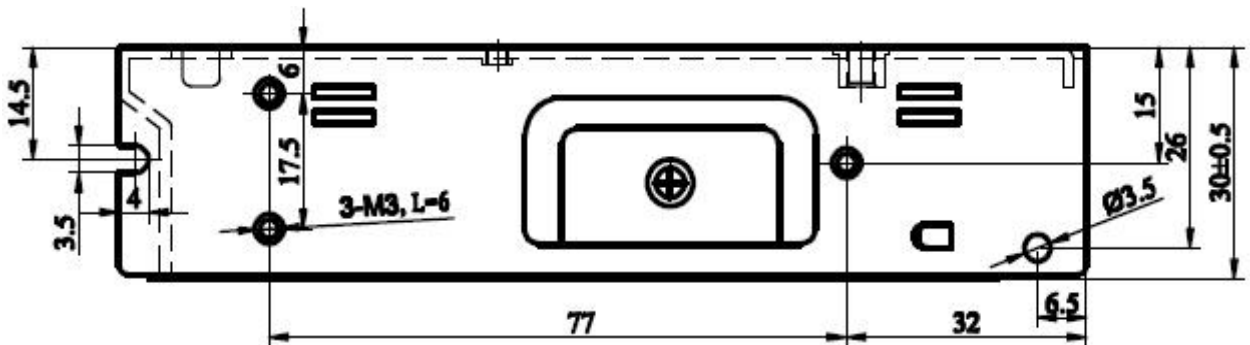
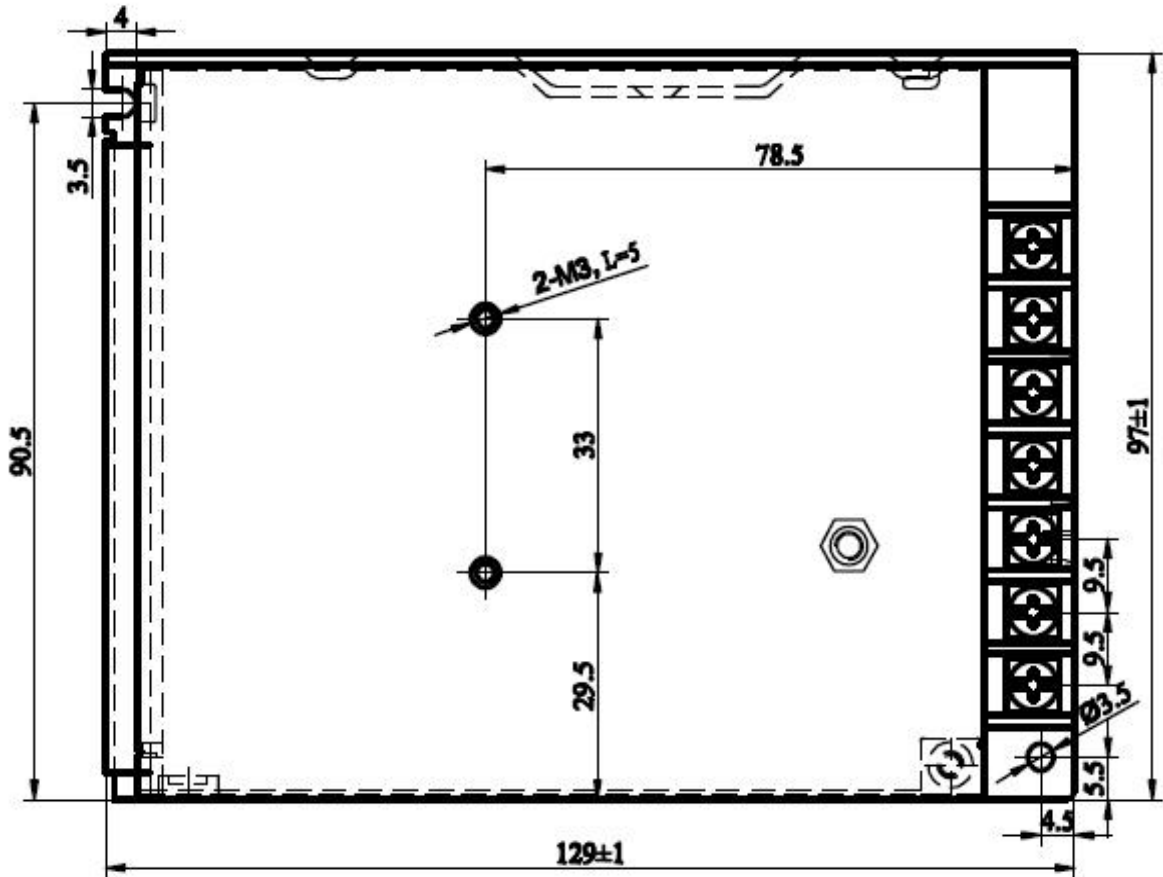

Pin No.	Assignment	Pin No.	Assignment
1	AC/L	4	DC output (V-)
2	AC/N	5	DC output (V+)
3	FG		