



Product Brief 2011

Power Factor Correction

PhaseCap Premium for Power Quality Solutions

The PhaseCap® series has been the product hero in PFC since its introduction. Using a polypropylene film with zinc/ aluminum alloy as dielectric (MKK technology), the PhaseCap series provides excellent performance and a very high reliability. The unique winding technology offers high output ranges with small dimensions and low weight. Nowadays the PhaseCap Premium series is standard in a wide field of applications up to 800 V AC such as

- automatic PFC equipment, capacitor banks
- individual fixed PFC (e.g. motors, transformers, lighting)
- fast dynamic PFC
- harmonic filters

Types with voltages between 525 V AC and 800 V AC are the adequate products for wind turbines

and industrial applications with distorted networks or heavy loads.

The new series B25667C is based on the same well-proven characteristics of the predecessor series and additionally offers a broad variety of enhanced technical parameters:

- Higher inrush current withstand capability
- Enlarged number of switching operations
- Longer mean life expectancy
- Optimized safety terminal with high current capability
- Enhanced discharge resistors pre-mounted up to 690 V AC, external discharge module for 765 V AC and 800 V AC

PQS



PhaseCap Premium

Benefits

- Self healing design, inert gas impregnation
- Maintenance-free operation with highly constant capacitance, high temperature class, flame proof
- Enhanced shock hazard protection, no loosening of screws, reduced assembly costs
- Optimized manufacturing with statistical process control
- Long useful life with minimum FIT rate
- Use of non-hazardous materials
- Easy, environmentally friendly disposal, no risk of oil leakage due to dry design
- Certification: GOST, cUL (up to 690 V AC)

Features

Voltage range:	230 ... 800 V AC
Output range:	5 ... 33 kvar
Frequency:	50/60 Hz
Design:	cylindrical aluminum can with stud
Dielectric:	polypropylene film
Impregnation:	inert gas
Safety:	dry technology, overpressure disconnecter, self healing
Terminal:	Optimized safety terminal with high current capability
Discharge module:	ceramic, pre-mounted for series up to 690 V AC, external discharge module for 765 and 800 V AC
Ordering code:	for particular ordering codes please refer to the PFC product profile, actual version

Electrical parameters

- Inrush current withstand ability: up to $300 \cdot I_R$
- Overcurrent capability: up to $1.6 \cdot I_R$ incl. combined effects of harmonics, overvoltages and capacitance tolerance
- Mean life expectancy: up to 180 000 h at temperature class -40/C
up to 130 000 h at temperature class -40/D
- Number of switching operations: max. 7500 switchings acc. IEC 60831-1+2
- Dimensions: height (h) up to 200 mm
diameter (d) up to 136 mm

Dimensional drawings

Capacitor up to 690 V AC series

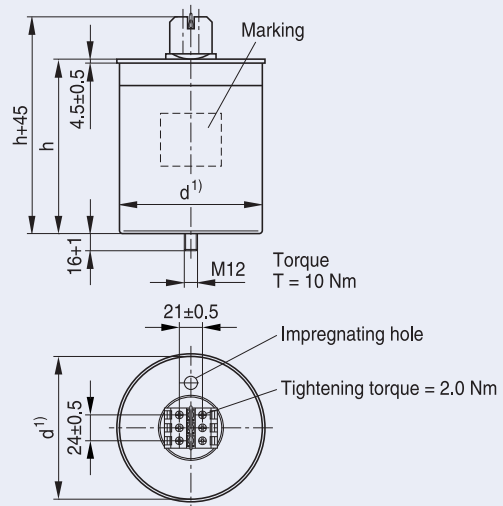

¹⁾ Seaming adds 5.5 mm in diameter

KLK1841-I-E

Capacitor 765 and 800 V AC series

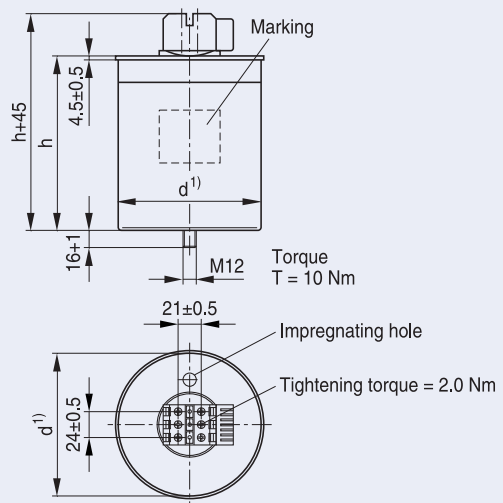

¹⁾ Seaming adds 5.5 mm in diameter

KLK1834-I-E

PhaseCap Premium

Technical data and limit values

Standards IEC 60831-1+2, EN 60831-1+2, UL 810 5th edition

Overvoltage	V_{\max}	$V_R + 10\%$ (up to 8 h daily) / $V_R + 15\%$ (up to 30 min daily) $V_R + 20\%$ (up to 5 min daily) / $V_R + 30\%$ (up to 1 min daily)
Overcurrent	I_{\max}	up to $1.6 \cdot I_R$ including combined effects of harmonics, overvoltages and capacitance tolerance
Inrush current	I_s	up to $300 \cdot I_R$
Losses: - Dielectric - Total*		< 0.2 W/kvar < 0.45 W/kvar
Rated frequency	f	50/60 Hz
Capacitance tolerance		-5% / +10%
Test voltage, terminal / terminal	V_{TT}	$2.15 \cdot V_{R1}$, AC, 10 s
Test voltage, terminal / case	V_{TC}	up to $V_R \cdot 660$ V: 3000 V AC, 10 s; above $V_R = 660$ V: 6000 V AC, 10 s
Mean life expectancy	$t_{LD(Co)}$	up to 180 000 h (temperature class -40/C) up to 130 000 h (temperature class -40/D)
Ambient temperature		-40/D; max. temp. 55 °C, max. mean 24 h = 45 °C; max. mean 1 year = 35 °C; lowest temperature = -40 °C
Cooling		natural or forced
Humidity	H_{rel}	max. 95%
Altitude		max. 4000 m above sea level
Mounting position		upright/horizontal
Mounting and grounding		threaded M12 stud on bottom of case
Safety		dry technology, overpressure disconnecter, self-healing, maximum allowed fault current 10 000 A in accordance with UL 810 standard
Discharge module		ceramic discharge module pre-mounted up to 690 V; external discharge module for 765 V and 800 V
Case		extruded aluminum can
Enclosure		IP20, indoor mounting (optionally with terminal cap for IP54)
Dielectric		polypropylene film
Impregnation		inert gas, Nitrogen (N ₂)
Terminals		optimized capacitor safety terminal with electric shock protection (IP20), (VDE 0106 part 100), max. 25 mm ² cable cross-section, max. current 80 A
Certification		cUL file # E238746 up to 690 V, GOST
Number of switching operations		max. 7500 switching operations per year

Important information: Some parts of this publication contain statements about the suitability of our products for certain areas of application. These statements are based on our knowledge of typical requirements that are often placed on our products. We expressly point out that these statements cannot be regarded as binding statements about the suitability of our products for a particular customer application. It is incumbent on the customer to check and decide whether a product is suitable for use in a particular application. This publication is only a brief product survey which may be changed from time to time. Our products are described in detail in our data sheets. The Important notes (www.epcos.com/ImportantNotes) and the product-specific Cautions and warnings must be observed. All relevant information is available through our sales offices.